

# V.P. Rental, Sales, & Service

www.villeplatterental.com

805 W. Dardeau St.

Phone: (337) 363-0461

## *Equipment Catalog*



american rental association

## **Renting: The Smart Way To Get Things Done.**

### **Normal Store Hours**

Monday - Friday . . . . .	*8:00 a.m. to 5:00 p.m.
Saturday . . . . .	*8:00 a.m. to 12:00 noon

\* 7:30 a.m. for Contractors

**PLEASE CALL FOR CURRENT PRICING.  
PH#337-363-0461**

# V.P. Rental, Sales, & Service

www.villeplatterental.com

805 W. Dardeau St.

Phone: (337) 363-0461

## 12 Good Reasons to Think Rental

© The American Rental Association

1. **Minimum Inventory** - Ownership can be very expensive when equipment is idle. Combining ownership of basic equipment with rental equipment as needed will minimize idle time.
2. **Right Equipment for the Job** - Eliminate the hidden costs of inefficiency due to use of wrong size or type of equipment and the maintenance and repair incurred. Rental equipment ensures the right equipment for the job.
3. **Warehousing** - Use of rental equipment eliminates the need for large storage areas/buildings, thus, overhead in your cost of doing business is minimized.
4. **Breakdowns** - Virtually all equipment is subject to occasional breakdowns. However, when rented equipment breaks down, idle time is minimized through replacement by the rental company, and repair costs are eliminated.
5. **Maintenance** - Rented equipment includes full maintenance, no repair shop, no spare parts inventory, no mechanics, no added maintenance payroll or maintenance recordkeeping.
6. **Inventory Control** - The presence of continuous billing on rented equipment establishes personal accountability. Inventory loss due to pilferage is minimized.
7. **Disposal Costs** - Preparing used, obsolete equipment for resale, advertising and selling time are factors of ownership that do not occur in renting.
8. **Cost Control** - Knowing the true costs of owned equipment is difficult. Rented equipment offers you just one accountable cost figure, the rental invoice cost.
9. **Equipment Obsolescence** - Ownership of equipment involves the risk of rising wage costs and slower job completion time due to owning worn, obsolete models when new, better, faster models are available from our rental company.
10. **Taxes/Licenses** - Personal property taxes and license costs are eliminated on rental equipment.
11. **Conservation of Capital** - Renting construction equipment frees your capital for other potentially more profitable uses.
12. **Increase in Borrowing Capacity** - Contractors who rent instead of purchase find borrowing easier with better ratio of assets to liabilities since equipment does not appear as a liability on the balance sheet. The normal line of bank credit is not disturbed, a most important asset in securing bonds for construction work.

---

## Definitions

**Renting** - is for a short or indeterminate period of time. It can be less than one day, or for as long as the customer wants it to be. The important thing is that the customer can return the rented item and pay for the time he has the equipment. The customer's charges and liability begin and end with the rental period - which the customer controls. Renting never includes a guaranteed period of time, and renting always includes maintenance.

**Leasing** - involves a contractually agreed upon period of time for which the customer agrees to terms that repay a portion of the purchase price of the equipment leased. Some leasing includes maintenance; most does not.

**Rent-to-own** - also involves a contract - often for as long as 52 weeks, or even 78 weeks, in which the customer buys the product, paying high interest rates. The customer has the option of returning it during the life of the contract. RTO centers offer a way to purchase merchandise to those who lack credit, can't make the down payment or are too poor to finance a purchase at a traditional department store.

Rent-to-own centers concentrate on home furnishings such as large-screen televisions, audio home entertainment centers, computers, furniture, jewelry and home appliances.

# V.P. Rental, Sales, & Service

www.villeplatterental.com

805 W. Dardeau St.

Phone: (337) 363-0461

## Table of Contents

Equipment	Page	Equipment	Page
Aerial Work Platforms	05	Floor Chemicals	25
Manlift		Generators, Lights, Welders	15
Scissor Lift		Grinders	15
Air Compressors	06	Ladders	16
Air Tools & Accessories	07	Lawn & Garden Equipment	16
Air Fastening Tools		Augers, Aerators, ATV Plow	
Automotive Tools & Equipment	08	Chain Saw	
Buffers, Floor Scrubbers,		Log Splitter, Mowers, Sod Cutter	
Polishers, Sanders, Sandpaper	09	Stump Grinder, Tillers, Trimmers	
Carpet, Floor & Tile Tools	10	Medical Equipment	27
Compaction Equipment	11	Miscellaneous	18
Concrete Equipment	11	Construction Equipment	
Demolition Tools		Decorating Equipment	18
Finishing Tools		Party Supplies	27
Cylinder Gases	26	Painting	19
Regulators	26	Plumbing & Drain Cleaning Tools	20
Decorating Equipment	19	Pressure Washers	19
Dollies, Hoists and Jacks	12	Saws	21
Drills	12	Scaffolds	22
Earthmoving Equipment	13	Surveying & Measuring Equipment	23
Backhoes, Tractors,		Trailers & Tow Dollies	23
Trenchers		Wall Paper	24
Fans, Blowers, Heaters	15	Water Pumps	24

**Equipment must be returned Clean or will have a \$30.00 charge.  
Heavy Equipment will have a \$50.00 cleaning charge  
Equipment must be returned full of fuel or charges will apply.**

### Rental Requirements

- Drivers License
- License plate number
- \$50.00 charge on all returned checks
- All rentals paid in full in advance
- Sales tax added to all rentals
- All checks over \$100.00 will be confirmed by your bank
- Charges are for time out not time used
- Please avoid a \$30/\$50 fee by returning equipment clean

# V.P. Rental, Sales, & Service

www.villeplatterental.com

805 W. Dardeau St.

Phone: (337) 363-0461

## How to find us

From I-49 North (Opelousas) take exit 23 (HWY-167W). At the first traffic light in Ville Platte, Turn right onto Tate Cove Rd. At the very next traffic light, turn left onto Lincoln Rd. Go down approx. 1.5 miles to traffic light and turn right onto N. Dupre for 1 block. This will put you in front of our building.

From I-49 South take Exit 40 (HWY-29 South.). Go down approx. 6 miles until you come to a T-junction. Turn left following Hwy-29 S to the first traffic light. Turn right onto Lincoln Rd. Go down approx. 1.5 miles to the next traffic light and turn right onto N. Dupre for 1 block. This will put you in front of our building.

From Oakdale: take Hwy 10 East until you reach Ville Platte, at the First Traffic Light (at Citizens bank) take a left on Dupre St, Go Down 6-7 blocks to the end at a T-junction/Stop Sign. Look Up, there we are!

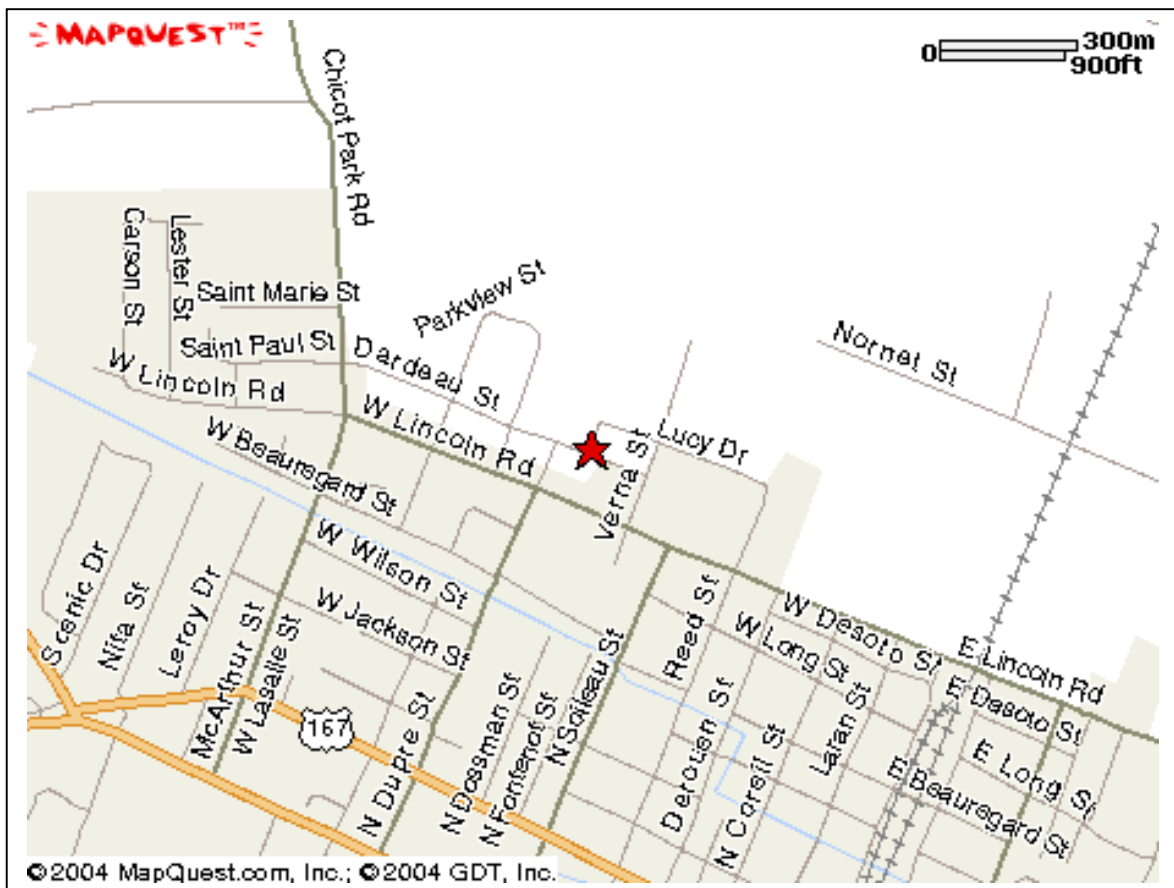

# V.P. Rental, Sales, & Service

www.villeplatterental.com

805 W. Dardeau St.

Phone: (337) 363-0461

Item	Minimum	1 Day	5 Day	1 Week	4 Weeks
------	---------	-------	-------	--------	---------

## AERIAL WORK PLATFORMS

### 103 MANLIFT

Bil-Jax XLB-4232 Tow-able Telescopic Boom	160.00	190.00	570.00	760.00	2280.00
---	--------	--------	--------	--------	---------

**\$ 150.00 Deposit on rental.**

- A durable lift constructed of heavy-duty steel, with a 40qworking height. Platform load rated at 300 lbs.
- **Advantage:** Small outrigger pattern provides more usable side reach for the user.
- 15" tires, a safety harness/lanyard are standard on the XLB-4232.  
(Safety Harness is mandatory) The unit has a 275 lbs. Tongue Weight.

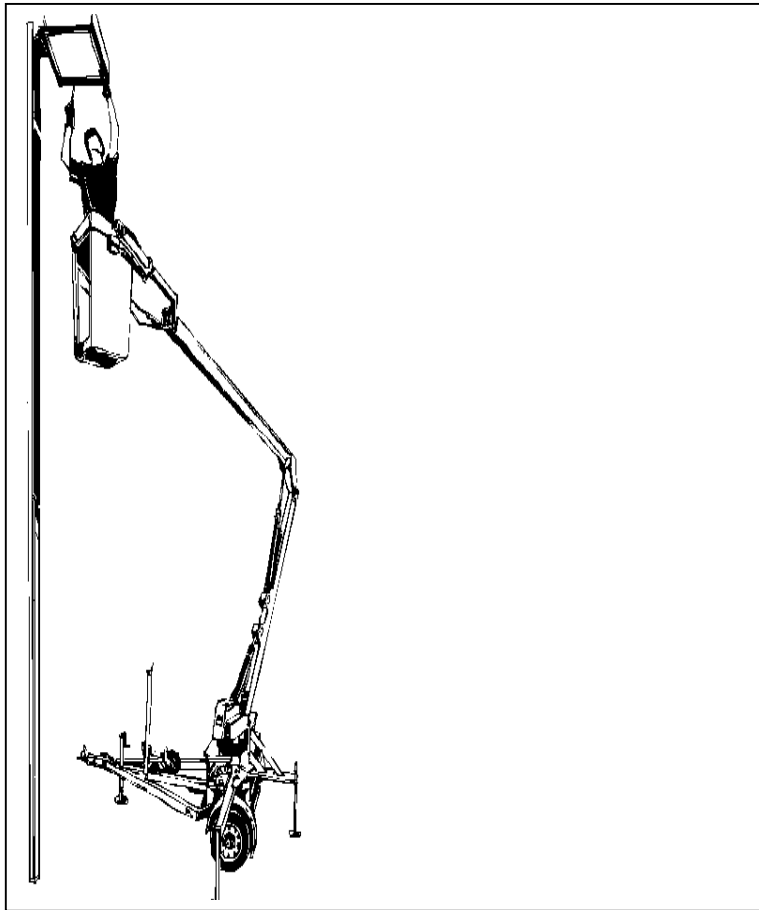

### 103 SCISSOR LIFT (Interior use only)

25qworking height 19qplatform height. Platform capacity 500lbs extension capacity 250lbs. Platform stowed 71.5+extended107.5+Wheel base is 52+X 30+turning radius is 61+unit weight is approx. 3214lbs.

<b>Combo rental with 10ft trailer, chains &amp; binder</b>	195.00	580.00	775.00	2325.00
--	--------	--------	--------	---------

# V.P. Rental, Sales, & Service

www.villeplatterental.com

805 W. Dardeau St.

Phone: (337) 363-0461

Item	Minimum	1 Day	1 Week	4 Weeks
<b>100 AIR COMPRESSOR</b>				
<b>Tow-Diesel</b> (needs a <b>2 5/16"</b> ball)				
Capacity - 185 cfm      Fuel - Diesel,	85.00	110.00	550.00	1600.00
<b>Compressor Package – Diesel</b>				
<b>Includes 90# Jackhammer, Bits, Hose.</b>		140.00	700.00	2100.00
<b>Gas</b>				
5 hp 11.5 cfm @ 100 psi	35.00	50.00	150.00	450.00
5.5 hp 8.9 cfm @ 100 psi	35.00	50.00	162.00	486.00
<b>Electric</b>				
11.5 cfm @ 100 psi	35.00	50.00	150.00	450.00

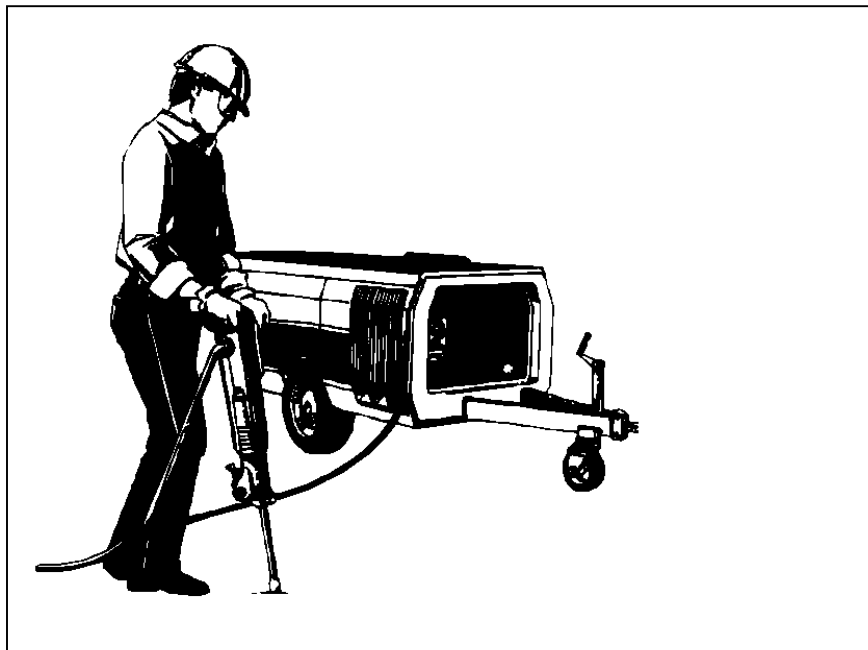
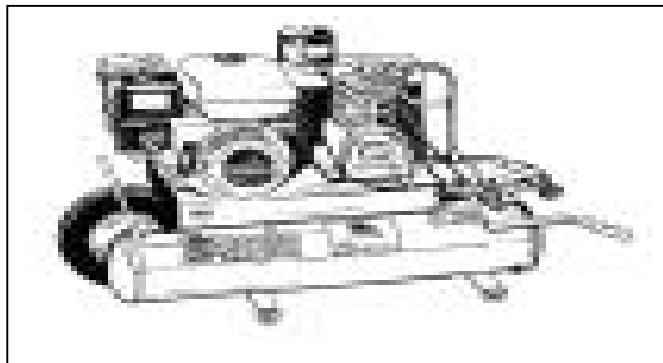

# V.P. Rental, Sales, & Service

www.villeplatterental.com

805 W. Dardeau St.

Phone: (337) 363-0461

Item	Minimum	1 Day	1 Week	4 Weeks	
<b>AIR TOOLS &amp; ACCESSORIES</b>					
173	<b>Jack Hammer 90 Lb. – use w/diesel</b>	35.00	46.00	138.00	414.00
173	<b>Jack Hammer 30Lb *</b>	30.00	40.00	160.00	480.00
	*Use portable air compressor (gas or electric) With small air hammer (30Lb)				
	<i>see bits below</i>				
164	<b>Jack Hammer BITS:</b>	-----			
	Asphalt Spade (1 1/8, 1 1/4)	13.00	36.00	72.00	
	Chisel(s) (1 1/8, 1 1/4 shank sizes)	9.00	24.00	72.00	
	Point(s)	9.00	24.00	72.00	
173	<b>FASTENING TOOLS</b>				
173	Stapler AIR	15.00	25.00	100.00	300.00
173	Finishing nail gun AIR 16g nails	15.00	25.00	100.00	300.00
173	Framing nail gun AIR- lip nails, 2+3.5+		25.00	75.00	150.00

**Shot Nails (100 per Box)**

Nails w/o washers

- 2-in. 4.50 per box or .05 per nail
- 2 1/2-in. 4.50 per box or .05 per nail
- 3-in. 4.50 per box or .05 per nail

Nails w/ washers

- 2 1/2 -in. 8.95 per box or .10 per nail
- 3-in. 8.95 per box or .10 per nail

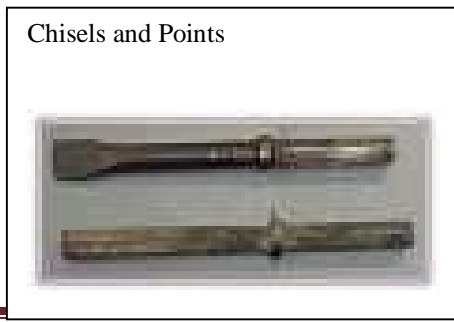
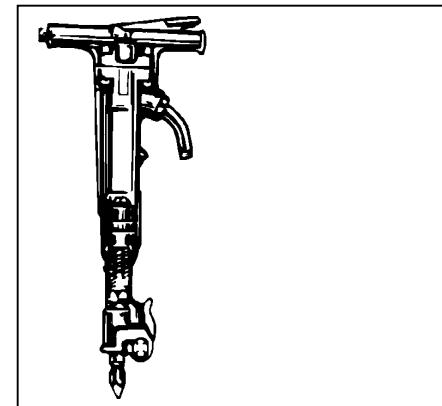
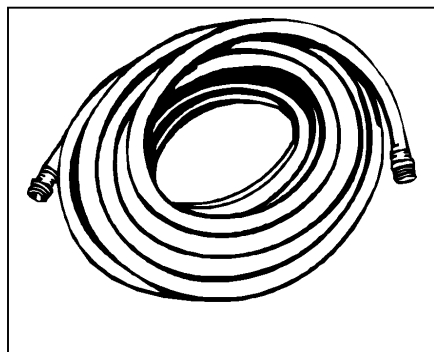
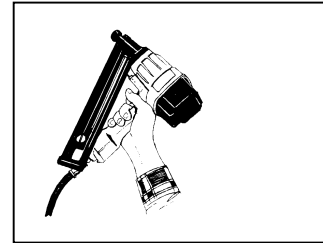

[Type text]

# V.P. Rental, Sales, & Service

www.villeplatterental.com

805 W. Dardeau St.

Phone: (337) 363-0461

Item	Minimum	1 Day	1 Week	4 Weeks
<b>AUTOMOTIVE TOOLS &amp; EQUIPMENT</b>				
170	Impact Wrench ½in. <b>Electric</b>	20.00	80.00	240.00
176	Bolt Cutters 36+inch.	10.00	30.00	60.00
196	Car Polisher	18.00	54.00	108.00
195	Engine Hoist, Knockdown	35.00	110.00	330.00
195	Engine Hoist, Towable (2+ball-2500lbs.)	35.00	110.00	330.00
102	Transmission Jack <ul style="list-style-type: none"> <li>• Designed for the removal and installation of auto and light truck transmissions or transfer cases</li> <li>• Wide stance steel frame features reinforced steel side plates that double as tool trays</li> <li>• Heavy-duty steel ball bearing swivel casters</li> <li>• Fully adjustable saddle, corner brackets and safety chains</li> <li>• Speedy lift hydraulic pump for rapid lifting to contact point without load</li> <li>• Safety overload and top-of-stroke bypass system provides maximum pump protection</li> <li>• Pump handle swivels 360° for operation in any position</li> <li>• Easy-to-use pump hand control knob</li> <li>• Proof tested and certified</li> <li>• Complies with ANSI/ASME PALD-2 standards</li> </ul>	40.00	120.00	350.00
185	<b>Tow Dolly</b> (give safety instruction) \$10.00 Cash Deposit For Straps	48.00	65.00	220.00
				660.00

MAX. WIDTH 76+ MAX. WEIGHT 4300 LBS.

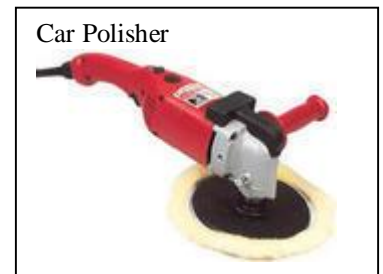
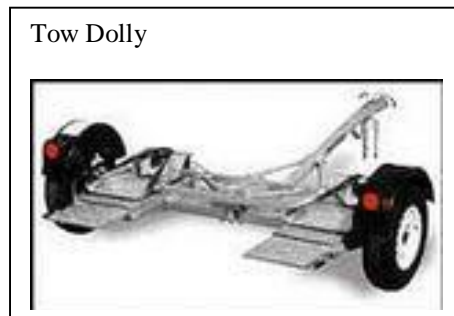
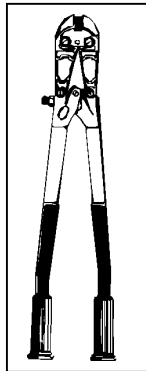



# V.P. Rental, Sales, & Service

www.villeplatterental.com

805 W. Dardeau St.

Phone: (337) 363-0461

Item	Minimum	1 Day	1 Week	4 Weeks
<b>174 BUFFERS, FLOOR SCRUBBERS, POLISHERS and SANDERS</b>				
8-in Drum	45.00	58.00	232.00	696.00
12-x18+ Sander - Orbital Floor Buffer	45.00	55.00	145.00	420.00
13+Sander - Floor Buffer/Scrubber	25.00	35.00	120.00	360.00
17+Sander/Polisher	40.00	55.00	145.00	420.00
17+Sandpaper Attachment - Floor Buffer	55.00	75.00	225.00	675.00
17+Stone Attachment - Floor Buffer	55.00	75.00	225.00	675.00
Sanding or Grinding Attachment		45.00	135.00	450.00
<b>174 Sanders Handheld:</b>				
3-in x 24-in. Sander - Belt	15.00	25.00	100.00	300.00
7-in. Sander Edger 7R - Floor Use under walls and floors	35.00	45.00	180.00	540.00
1/2 sheet . Sander Orbital	20.00	30.00	120.00	360.00
1/4 sheet . Sander Palm or Round				
<b>Floor Pads</b>				
12-x18+Black Scrubber	8.15ea.			
12-x18+Green Scrubber	8.15ea.			
12-x18+White Polisher	8.15ea.			
13-x2+ Black Stripper	7.55ea.			
13-x2+ White Polisher	7.55ea.			
17-x2+ Black Stripper	8.75ea.			
17-x2+ White Polisher	8.75ea.			
17-x2+Disc 80 Grit	4.45 ea.			
17-x2+Disc 60 Grit	4.50 ea.			
17-x2+Disc 36 Grit	5.50 ea.			
17-x2+Disc 20 Grit	7.65 ea.			
<b>SANDPAPERS</b>				
12-x18+100 Grit 2 Sided	7.75 ea.			
12-x18+100 Grit	4.99 ea.			
12-x18+80 Grit	4.87 ea.			
12-x18+60 Grit	5.23 ea.			
12-x18+36 Grit	5.65 ea.			
12-x18+20 Grit	6.45 ea.			
12-x18+120 Grit Screen	7.75 ea.			
12-x18+100 Grit Screen	7.75 ea.			
<b>Hand Belt Sander</b>				
3-x24+ 80 Grit	2.95 ea.			
3-x24+ 60 Grit	2.95 ea.			
<b>Floor Edger</b>				
7-x7/8+100 Grit	1.39 ea.			
7-x7/8+36 Grit	1.39 ea.			
7-x7/8+20 Grit	1.56 ea.			

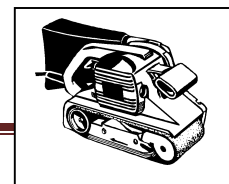

# V.P. Rental, Sales, & Service

www.villeplatterental.com

805 W. Dardeau St.

Phone: (337) 363-0461

Item Minimum 1 Day 1 Week 4Weeks

## Hand Orbital Sander

9x11+100 Grit	.99 ea.
9x11+ 60 Grit	.99 ea.
9x11+ 40 Grit	.99 ea.

## Drum Sander

8x19+100 Grit	2.85 ea.
8x19+ 80 Grit	3.20 ea.
8x19+ 60 Grit	3.00 ea.
8x19+ 36 Grit	3.50 ea.
8x19+ 20 Grit	7.50 ea.
<b>Stones</b>	<b>7.95 ea</b>

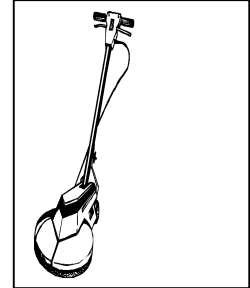

*Price is approximated on all sand associated items.*

## 109 CARPET, FLOOR & TILE TOOLS

	Carpet Cleaner, Hot Water- Sml/Lg	30.00	40.00	160.00	480.00
	Carpet Cleaner <b>Chemical</b>	<b>9.95 qt</b>	<b>16.95 gal</b>		
	Carpet Attachment . Upholstery	\$5.00			
	Carpet Iron	15.00	20.00	80.00	240.00
	Carpet Stapler, electric	14.00	20.00	80.00	240.00
	Carpet Stretcher for the Room	30.00	40.00	160.00	480.00
	Knee Kicker (used to position carpet)	8.00	15.00	60.00	180.00
	Linoleum Roller (With Wire Brush)	11.00	25.00	75.00	225.00
	Stair Tool	9.00	15.00	45.00	135.00
	Nailer . Hardwood Flooring				
	3/8 in. or 3/4 in. Tongue & Groove	10.00	20.00	60.00	180.00
	Wet Dry Vacuum/Commercial 10 gal	25.00	30.00	120.00	360.00
206	Carpet Blower/Dryer LARGE	25.00	35.00	125.00	375.00
206	Carpet Blower/Dryer SMALL	15.00	20.00	60.00	180.00
108	Tile Remover, Mini electric	20.00	28.00	60.00	175.00
108	Tile Remover, Manual	8.00	15.00	45.00	
108	Tile Remover, Electric	50.00	65.00	260.00	720.00
	<b>Blades Additional (part #¢, 28050 slicer \$22.95 each) (scraper part#¢ 28040 \$ 12.95)</b>				
175	Saw, Wet Tile w/Stand 10+	40.00	50.00	200.00	600.00
163	Saw, Sml hand held tile	20.00	35.00	125.00	375.00
	Tile Cutter				
	Vinyl (up to 12in.)	6.00	10.00	40.00	120.00
	Tile Cutter 12+ceramic	6.00	10.00	40.00	120.00
	Ceramic Hand held electric saw	20.00	25.00	75.00	200.00
	Linoleum Tile Cutter	20.00	25.00	75.00	200.00

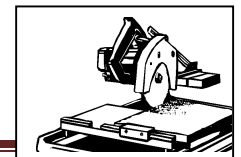
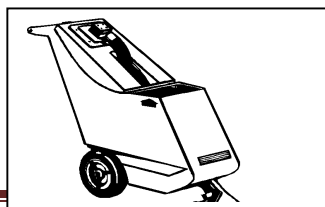
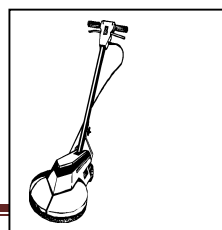
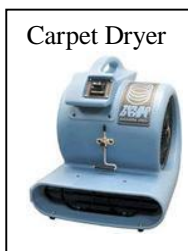

# V.P. Rental, Sales, & Service

www.villeplatterental.com

805 W. Dardeau St.

Phone: (337) 363-0461

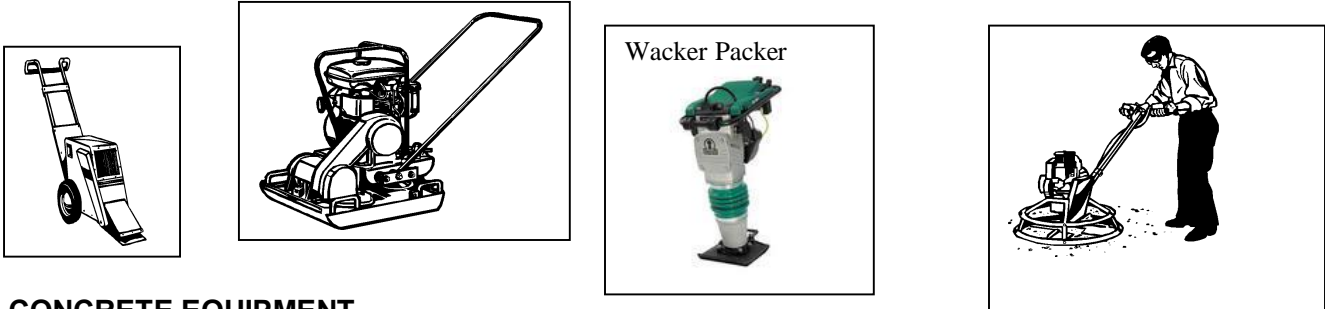
Item	Minimum	1 Day	1 Week	4Weeks
<b>160 COMPACTION EQUIPMENT</b>				
<b>Wacker Packer Hammer</b> MdlBs600 11-in. wide	60.00	70.00	225.00	600.00
<b>Wacker Packer Plate – Vibrating</b> 14+w/ water applicator	60.00	70.00	225.00	600.00
				
<b>161 CONCRETE EQUIPMENT</b>				
<b>Concrete Finishing Tools</b>				
Bull Float w/Three Handles Extra handles, 6 ft.	12.00	18.00	36.00	108.00
Hand Tools:				
Trowel Edge	5.00	5.00	15.00	45.00
Trowel Hand	5.00	5.00	15.00	45.00
Trowel Hand Magnesium Float	10.00	15.00	45.00	90.00
<b>164 Concrete Vibrator</b>	30.00	45.00	120.00	360.00
<b>165 WHIRLYBIRD Power Trowel</b>	50.00	60.00	165.00	
<b>173 Jack Hammers-AIR</b>				
90 lb. Jack Hammer . use w/diesel	35.00	46.00	138.00	414.00
30 lb. Jack Hammer*				
*Use portable air compressor (gas or electric) with small air hammer (see p. 6)	30.00	40.00	160.00	480.00
<b>164 BITS :</b>				
Asphalt Spade (1 1/8, 1 1/4)		13.00	36.00	72.00
Chisel(s) (1 1/8, 1 1/4 shank sizes)		9.00	24.00	72.00
Point(s)		9.00	24.00	72.00

# V.P. Rental, Sales, & Service

www.villeplatterental.com

805 W. Dardeau St.

Phone: (337) 363-0461

Item	Minimum	1 Day	1 Week	4 Weeks
------	---------	-------	--------	---------

## ELECTRIC DEMOLITION TOOLS

160	Jack Hammer <b>BRUTE</b> #11304- (3) Extra Bits \$ 15.00 Per Day	55.00	70.00	210.00	600.00
<b>Bosch Tools:</b>					
161	Demolition Hammer-small Jack or chipping	45.00	60.00	160.00	475.00
170	Drill Hammer- Rotary - 1 9/16" spline bit concrete only	25.00	35.00	105.00	315.00
	Bits, up to 1/2 %		11.00	33.00	99.00
	Bits, 9/16+to 1+		13.00	39.00	117.00
	Bits, 1-1/16+and up		15.00	45.00	135.00

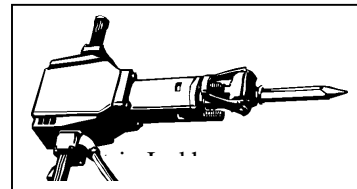
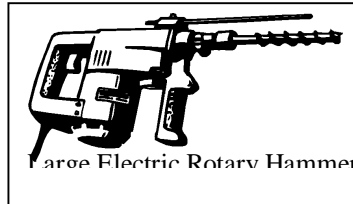
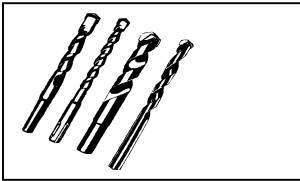

## 185 DOLLYS, HOISTS, AND JACKS

### Dollies

	Hand Truck (freight)	6.00	10.00	25.00	50.00
	Appliance Heavy Duty w/ straps	10.00	16.00	50.00	100.00
	Piano	5.00	8.00	15.00	30.00
176	Mule Bar	5.00	7.00	15.00	30.00
102	<b>Chain Hoists 20 ft. Lift</b>				
	1 Ton	15.00	20.00	40.00	80.00
	2 Ton	25.00	30.00	60.00	120.00
	3 Ton	35.00	40.00	80.00	160.00
	Portable Winch 1500 lbs.	30.00	40.00	160.00	300.00
102	Pallet Jack 5000Lb capacity 27x48 13 id	26.00	40.00	100.00	300.00
107	Drywall Lift, 10 ft. - 150 lb.	35.00	50.00	100.00	250.00
109	Drywall Screw Gun	10.00	15.00	75.00	240.00
102	Transmission Jack	35.00	42.00	150.00	450.00
	Bottle Jack 12.5-Ton Hydraulic (1)	10.00	15.00	45.00	120.00
	Bottle Jack 22.5-Ton Hydraulic (3)	15.00	20.00	45.00	200.00

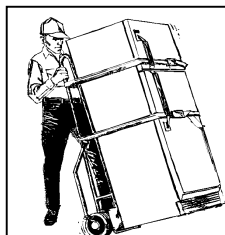

Sheet Rock

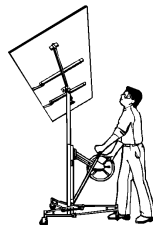

22.5 ton Hydraulic Jack



# V.P. Rental, Sales, & Service

www.villeplatterental.com

805 W. Dardeau St.

Phone: (337) 363-0461

Item	Minimum	1 Day	1 Week	4 Weeks
<b>170 DRILLS</b>				
Drill Right Angle (Black & Decker-1/2-)		39.00		
Drill 3/8-in. SDS hammer- concrete	20.00	25.00	45.00	90.00
Drill 3/4-in. Hammer Spline	25.00	30.00	80.00	240.00
<i>See bit prices page 11</i>				
Drill 1/2-in. Electric		15.00	45.00	90.00
Drill Anchor Trailer House	40.00	50.00	150.00	450.00

**ALL BITS SOLD SEPARATELY**

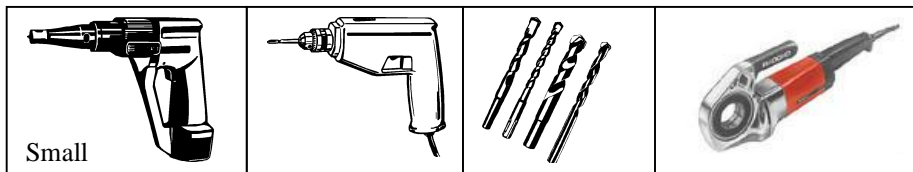

Item	Minimum	1 Day	(5 days)	(7Days)	4 Weeks
<b>EARTHMOVING EQUIPMENT</b>					
<b>146 SKID STEER Bobcat 753 Loader- 4cylinder</b>					
					<b>Deposit: 300.00</b>
	140.00	160.00	640.00	1920.00	
<b>BobCat 753 W Trailer &amp; Chains &amp; Binders</b>		210.00	620.00	1035.00	3622.00
<b>Capacities:</b> Bobcat height 9.5 ft					
*Weight- 4,732 lbs. *Fork capacity- 1,300 lbs.					
. *Travel speed- 6 mph *Radiator- 3 gal.					
*Tipping Load- 2,600 lbs.					
*40 H.P. Diesel Fuel- 40 gal.					
<b>Accessories:</b>					
<b>145 SKID STEER Auger Drive - Hydraulic</b>		85.00	235.00	340.00	680.00
w/1 bit-3 different sizes 6+8 1/2+12+		<b>Extra Bit \$ 20.00 Per Day</b>			
<b>146 SKID STEER Forks OR Bucket-750 lbs.</b>		50.00	150.00	200.00	
		<b>For Both attachments add additional:</b>			
		50.00	150.00	200.00	
<b>148 KUBOTA TRACTOR w/ Frt/End Loader L3010</b>					<b>Deposit: 300.00</b>
	160.00	190.00	600.00	950.00	3325.00
<b>Kubota W/Trailer Chains &amp; Binders</b>		240.00	720.00	1200.00	3600.00
<b>Accessories</b>					
Box Blade	35.00	45.00	105.00	175.00	370.00
5qBush Hog Shredder- model 285		50.00	180.00	250.00	420.00
<b>Remind customer to Keep screen in front of radiator clean if using Bush Hog.</b>					

# V.P. Rental, Sales, & Service

www.villeplatterental.com

805 W. Dardeau St.

Phone: (337) 363-0461

Item	Minimum	1 Day	5Days	1 Week	4 Weeks
<b>147 EXCAVATOR Bobcat 425</b> <span style="color: red;">Deposit \$500.00</span>					
8-ft- 12+& 16+wide bucket	190.00	230.00	690.00	1000.00	3000.00
<b>Bobcat 425 W/16' Trailer Chains &amp; Binders</b>		280.00	840.00	1300.00	3900.00
<b>Capacities: MUST GO ON 20' TRAILER</b>					
*Weight- 6,145					
*Diesel cap.- 14 gal.					
*Lifting cap.-913 LB					
*8-ft., 3-in. (2512 mm) digging depth					
*13-ft., 10-in. (4225 mm) reach at ground level					
<b>146</b> Extra Bucket		35.00	105.00	145.00	420.00
Thumb, Grappel		50.00	150.00	250.00	750.00
<b>148 TERRAMITE Backhoe / Front-end Loader-4ft.</b> <span style="color: red;">Deposit: 150.00</span>	130.00	160.00	480.00	640.00	1120.00
<b>Terramite W/ Trailer Chains &amp; Binders</b>		210.00	620.00	1035.00	3622.00
*Buckets-8+36+ *8qdigging depth *weight-2720lbs *40 HP					
<b>149 Walk Behind TRENCHERS w/ trailers</b>					
Trencher <b>1030H</b> 5-in.wide x 24-in.deep(tire width 33+)	110.00	130.00	390.00	520.00	1560.00
Trencher <b>1820</b> 5-in. wide x 36-in. deep (tire width 37+)	125.00	140.00	420.00	560.00	1680.00
Trencher <b>RT12</b> 4+x24+wide 33+ <b>With backfill</b>	125.00	145.00	435.00	580.00	1740.00
Trencher <b>RT-20</b> 4x36+ditch witch	145.00	160.00	490.00	640.00	1920.00
<b>Trencher Backfill available for additional</b>	<b>\$10.00</b>				

All Equipment returned must be clean and full of fuel or additional charges will be applied!!!!!!!!!!!!

**\*\*Do not leave key in the on position. Engine Timer will run. \*\***  
**( Day rate consists of 8 hrs. of running time)**



# V.P. Rental, Sales, & Service

www.villeplatterental.com

805 W. Dardeau St.

Phone: (337) 363-0461

Item	Minimum	1 Day	1 Week	4 Weeks
<b>206 FANS, BLOWERS &amp; DEHUMIDIFIERS</b>				
<b>HEATERS</b>				
Kerosene Heaters				
Forced Air 125,000 Btu		45.00	150.00	405.00
<b>FANS</b>				
24-in. Round (1 in stock)		20.00	60.00	180.00
42-in. Round (2 in stock)	25.00	40.00	75.00	225.00
Port-A-Kool WEEKEND RENT ONLY		150.00	450.00	1350.00
Filler Buckets 2 price ea.		30.00	90.00	270.00

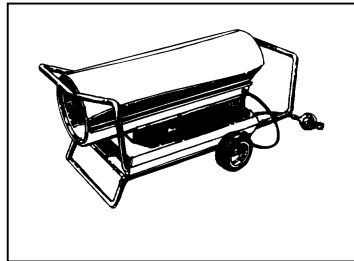
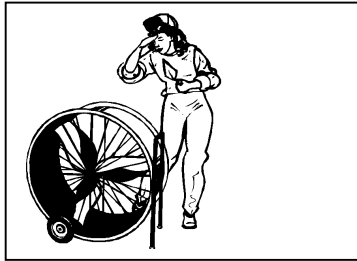

## 101 GENERATORS, LIGHTS, W ELDERS

Generators, Portable Gas

5500 watt Running 8500 Starting 40.00 60.00 240.00 720.00

*Generator rental rate consist of 12 hours on the meter. Additional hours are billed at \$3.00 per Hour. Generators require the oil to be changed every 24 hours of run (meter) time. The customer is responsible for oil changes during the rental period.*

***In order to reserve a generator it has to be rented for a minimum of 3 days.***

## 106 Lights

500 Watt Quartz, Twin Head

15.00 60.00 180.00

## 111 Welders (requires a 2+ball)

Miller Blue Star 6000, Diesel 180 AMP

55.00 70.00 280.00 840.00

## 171 GRINDERS

Grinder 4.5-in. Angle 110V

10.00 15.00 60.00 180.00

Grinder 7-in. Angle 110V

15.00 20.00 80.00 240.00

## 133 STUMP GRINDER, 25 HP TOWABLE

(2-in ball)- Mdl 337

95.00 135.00 540.00 1620.00

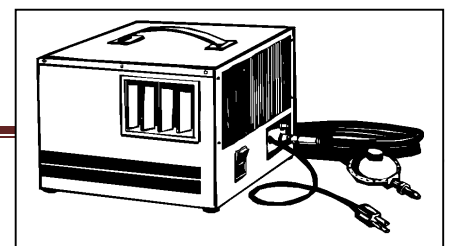
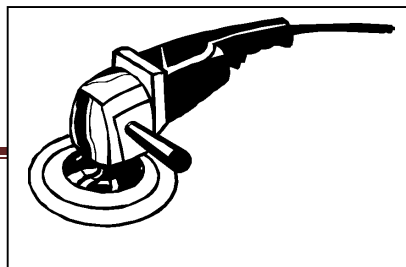
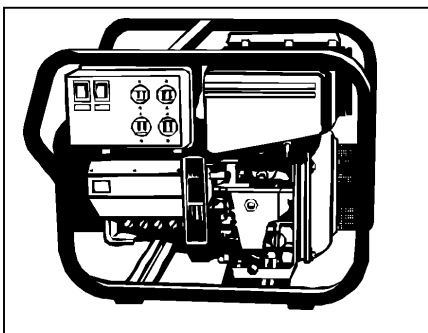

# V.P. Rental, Sales, & Service

www.villeplatterental.com

805 W. Dardeau St.

Phone: (337) 363-0461

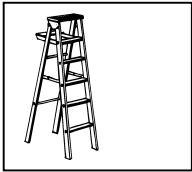
Item	Minimum	1 Day	1 Week	4 Weeks
<b>103 LADDERS</b>				
6 ft. Step Ladder	7.00	10.00	40.00	120.00
8 ft. Step Ladder	10.00	28.00	84.00	252.00
28 ft. Extension Ladder	21.00	28.00	112.00	336.00
				
<b>LAWN &amp; GARDEN EQUIPMENT</b>				
<b>132 PLUG Aerator</b>				
Walk-Behind Plug Aerator- Bluebird	55.00	70.00	280.00	840.00
<b>145 Augers</b>				
Post Hole Digger, Hand		10.00	30.00	90.00
BT 121 . 1 Man 2 Stroke 8+Bit Max.	40.00	55.00	220.00	660.00
1 or 2 Man Gas Power	50.00	60.00	240.00	720.00
Auger Side Boring up to12qft gas	125.00	150.00	600.00	1800.00
Accessories:				
(1 man auger has 4+, 6+, 8+, 12+bits and 1-12+extension; Mode1 1M5C)				
(2 man auger has 4+, 6+, 8+, 10+, 12+bits and 1-12+extension)				
Extension for 1or 2 man	5.00			
Extra Auger	8.00			
<b>131 ATV PLOW 48" 6 Disc 250cc or above.</b>	30.00	40.00	160.00	480.00
<b>129 Log Splitter, 34-Ton Vert./ Horz. 24" log</b>	60.00	75.00	300.00	900.00
Model L203-280035				
<b>133 Stump Grinder, 25 hp Towable</b>	95.00	135.00	540.00	1620.00
(2-in ball)- Mdl 337				
<b>130 Mowers</b>				
Mower 20+Toro Self Propel				
Mower 21+ Ariens Push				
Mower Kee 22+Hi-Wheel Push	25.00	35.00	140.00	420.00
Mower Kee 24+Hi-Wheel Self Propel	35.00	45.00	180.00	540.00
Mower Brush Cutter-				
Hi-Wheel Self Propel	65.00	80.00	320.00	960.00
<b>126 Edger, Sidewalk, Gas</b>	20.00	35.00	140.00	420.00
<b>134 Trimmer Walk Behind Ariens</b>	30.00	45.00	100.00	300.00
<b>128 Sod Cutter, 18in.</b>				
Blue Bird Sod Cutter	55.00	70.00	280.00	840.00
(Model Nev test)				



# V.P. Rental, Sales, & Service

www.villeplatterental.com

805 W. Dardeau St.

Phone: (337) 363-0461

Item		Minimum	1 Day	1 Week	4 Weeks
128	<b>Wheelbarrow</b>	10.00	15.00	60.00	180.00
131	<b>Broadcast Spreader 10,000 Sq FT</b>		10.00	30.00	90.00
131	Yard Poly Roller (Filled Weight #550)	25.00	30.00	120.00	360.00
132	Drop Spreader	20.00	35.00	140.00	420.00
132	25 Gal. Spray Rig. For ATV or Mower.	30.00	40.00	160.00	480.00
128	<b>Tillers</b>				
	Mini 3 HP, (Flower Bed)	25.00	35.00	140.00	420.00
	Tiller Front Tine	45.00	55.00	220.00	660.00
	Tiller Mid Size	45.00	55.00	220.00	660.00
	Tiller Mid Tine	45.00	55.00	220.00	660.00
	Tiller Rear Tine - BCS Model 710	45.00	55.00	220.00	660.00
	Tiller/Trencher Attachment				
	2+Trencher or <b>Edger Blade</b> for 5 HP tiller	15.00	15.00	60.00	180.00
	<b>Trimmers</b>				
127	Hedge Trimmer, Gas	20.00	30.00	120.00	360.00
	Hedge Trimmers, Electric	20.00	30.00	120.00	360.00
134	Trimmer Stihl String	30.00	45.00	180.00	540.00
134	Trimmer with brush knife Stihl	35.00	50.00	150.00	600.00
134	Trimmer Ariens walk behind string	30.00	45.00	180.00	524.00

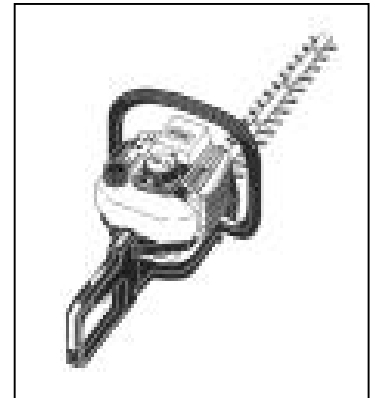

# V.P. Rental, Sales, & Service

www.villeplatterental.com

805 W. Dardeau St.

Phone: (337) 363-0461

Item	Minimum	1 Day	1 Week	4 Weeks	
<b>MISCELLANEOUS EQUIPMENT</b>					
<b>CONSTRUCTION EQUIPMENT</b>					
176	Bolt Cutter Lg and Med	5.00	8.00	32.00	96.00
	C Clamps	5.00	8.00	32.00	96.00
176	Post Driver	5.00	10.00	30.00	90.00
176	T Post Puller		5.00	15.00	
172	Hammer Claw, 16 oz.	5.00	8.00	32.00	96.00
176	Magnetic Bar	15.00	30.00	120.00	360.00
108	Tile Remover Manual	8.00	15.00	45.00	180.00
108	Tile Remover Electric	50.00	65.00	260.00	780.00
	Blades (part # 28040 for Vinyl Tiles scraper \$10.95, 28050 for Solid Vinyl slicer \$ 18.95)				
176	Metal Detector	20.00	35.00	140.00	420.00
176	Router (electric)	15.00	25.00	75.00	160.00
176	Cord Extension	5.00	5.00	20.00	80.00
	Lighted Arrow sign free-standing		50.00	120.00	240.00
176	Shovel		5.00	20.00	60.00
176	Pick Ax		8.00	32.00	
104	<b>DECORATING EQUIPMENT</b>				
	Acoustic Hopper Gun	15.00	20.00	80.00	240.00
	Hopper w/Compressor		50.00		

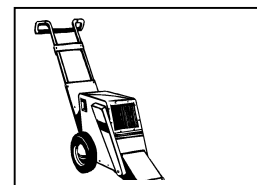
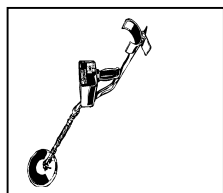
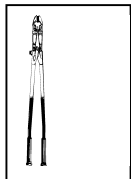

# V.P. Rental, Sales, & Service

www.villeplatterental.com

805 W. Dardeau St.

Phone: (337) 363-0461

<u>Item</u>	<u>Minimum</u>	<u>1 Day</u>	<u>1 Week</u>	<u>4 Weeks</u>
<b>105 PRESSURE WASHERS</b>				
2000 psi, Gas: Honda Powered	45.00	60.00	240.00	720.00
3000 psi, Gas: Landa; MiT-M #GW30043MGH	55.00	70.00	280.00	840.00
Hydro Spin Brush	15.00	25.00	100.00	300.00
Extension Wand 6qto 18qreach 4000psi max		15.00	60.00	

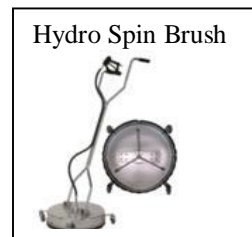
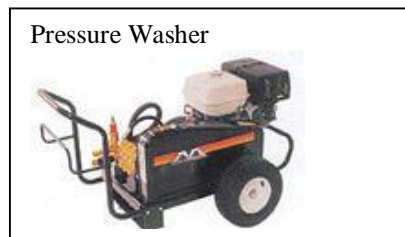

## 104 PAINT SPRAYER, AIRLESS

3300 PSI Variable Little pro ( <i>ALL PAINTS</i> )	50.00	75.00	300.00	800.00
--	-------	-------	--------	--------

# V.P. Rental, Sales, & Service

www.villeplatterental.com

805 W. Dardeau St.

Phone: (337) 363-0461

Item	Minimum	1 Day	1 Week	4 Weeks
<b>106 PLUMBING TOOLS</b>				
Pipe Threader Manual w/ 1 bit	10.00	15.00	60.00	180.00
Pipe Threader Electric w/ 1 bit	35.00	50.00	100.00	300.00
Extra Pipe Dies		8.00	32.00	96.00
Pipe Cutter 0-2 1/2+	8.00	12.00	48.00	144.00
Pipe Vise 6-in. w/stand	10.00	15.00	48.00	144.00
<b>196</b> Pipe Wrench 18#2+	5.00	8.00	30.00	90.00
<b>Snake, Hand Crank</b>				
1/4 -in. x 15 ft.		8.00	32.00	96.00
1/4 -in. x 25 ft.	7.50	15.00	60.00	180.00
1/2 -in. x 50 ft.	15.00	25.00	100.00	300.00
<b>Snake, Electric</b>				
1/2 -in. x 100 ft.	40.00	50.00	200.00	600.00
Mdl 5KC35JN41X				
1 1/2 -in. x 100 ft.	40.00	50.00	200.00	600.00
<b>Snake, Flat Rod</b>				
1/2-in. x 100 ft.	12.00	20.00	40.00	60.00
3/4 -in. x 100 ft.	15.00	25.00	50.00	75.00
<b>Super-Vee Drain Drill</b>				
5/16 in. x 25 ft.	20.00	35.00	140.00	420.00
<b>Water Ram Jet Drain Cleaner</b>				
Kinetic Water Ram	18.00	24.00	65.00	165.00

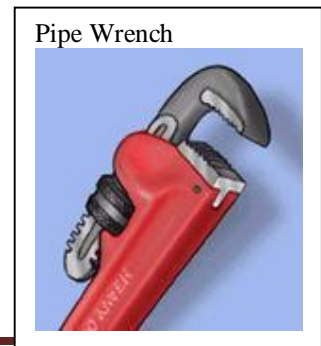
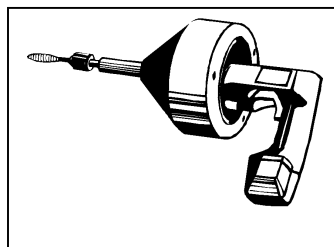
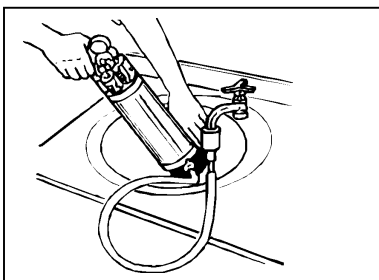
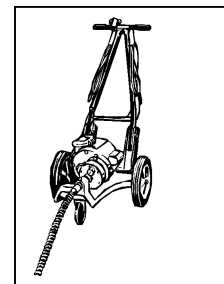
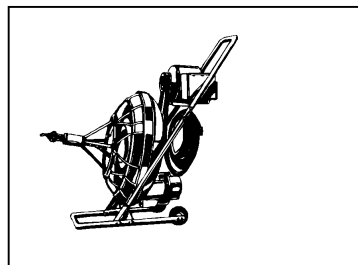
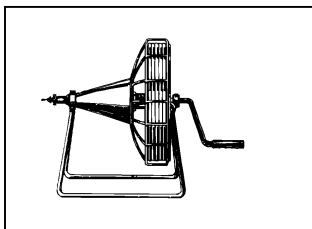

# V.P. Rental, Sales, & Service

www.villeplatterental.com

805 W. Dardeau St.

Phone: (337) 363-0461

Item	Minimum	1 Day	1 Week	4 Weeks	
<b>SAWS</b>					
175	<b>Chop Saw</b> , 14-in. Electric	15.00	25.00	100.00	300.00
125	<b>Chain Saws</b> (1 Gal. Gas mix & 1 Qt. Bar Oil)				
	16-in. Stihl (3)	38.00	48.00	192.00	576.00
	20-in. Stihl---(#310 goes out first) (2)	43.00	53.00	212.00	636.00
	25in. Stihl Chainsaw PRO (1)	53.00	68.00	272.00	816.00
	32in. Stihl Chainsaw	83.00	105.00	420.00	1260.00
	<b>12-ft Gas Pole Pruner</b>	53.00	63.00	252.00	756.00
	Harness	(\$5.00)			
175	Manual Pole Saw 18q	15.00	25.00	100.00	300.00
175	Extra Chains	8.00			
163	<b>Concrete Walk-Behind Edco saw</b> 16-in #DS1613H	50.00	65.00	260.00	780.00
	<b>Diamond Blade Usage-</b> <b>16-in. Abrasive wheels</b>				
		\$50.00 min. or \$2.50per Thousand			
		\$24.95 ea.			
163	<b>Saw Cut Off</b>				
	14-in. Electric	35.00	50.00	200.00	600.00
	14-in. Stihl Gas powered	43.00	63.00	252.00	756.00
	12-in. Abrasive wheels	\$10.95 ea.			
	14-in. Abrasive wheels	\$14.95 ea.			
175	<b>Door Jamb Saw</b> without Carbide Blade	25.00	35.00	140.00	420.00
175	<b>Door Jamb Saw</b> with Carbide Blade	25.00	35.00	140.00	300.00
175	<b>Jig Saw</b>	11.00	15.00	60.00	180.00
	<b>Blades sold separately</b>				
175	<b>Miter Saws</b>				
	10-in. Standard	15.00	25.00	100.00	
300.00					
175	<b>Sawzall (reciprocating)</b>	15.00	25.00	100.00	
300.00					
	<b>Blades sold separately</b>				
175	<b>Wet Tile Saws w/Stand 10-in.</b>	40.00	50.00	200.00	500.00
175	<b>16 Gauge Nibbler</b>	35.00	35.00	125.00	375.00
175	<b>Bow Saw</b>		10.00	20.00	30.00
163	<b>Small Handheld Tile Saw</b>	20.00	35.00	125.00	375.00
175	<b>7 1/2" Circular Saw</b>	15.00	25.00	100.00	300.00
	<b>Blade for circular saw</b>		3.00		

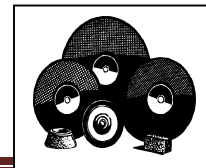
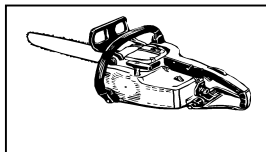
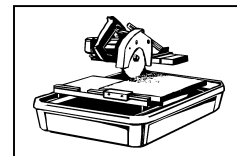
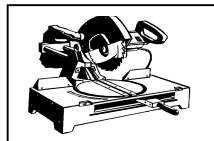
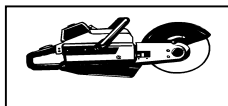

# V.P. Rental, Sales, & Service

www.villeplatterental.com

805 W. Dardeau St.

Phone: (337) 363-0461

Item	Minimum	1 Day	1 Week	4 Weeks
<b>107 SCAFFOLDS</b>				
Scaffold Outdoor 5 Ft		10.00	10.00	30.00
Scaffold Indoor 6Ft		30.00	30.00	90.00
<b>Accessories</b>				
Scaffold Guard Rail System		60.00	60.00	180.00
Scaffold Outrigger		10.00	10.00	30.00
Scaffold Jacks		8.00	8.00	32.00
Scaffold Wheels		10.00	10.00	30.00
Scaffold Walk boards 7+x 6q		10.00	10.00	30.00
Drywall lift, 11 ft. - 150 lb.		50.00	100.00	300.00
Scaffold Corner squaring brace		5.00	8.00	32.00
Walk Board 20x12+Aluminum for ladders w/Jack Leg		60.00	60.00	180.00
Scaffolding Hanger 4 pc		10.00	10.00	30.00
Scaffold feet set (4)				

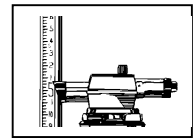
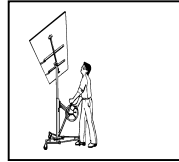
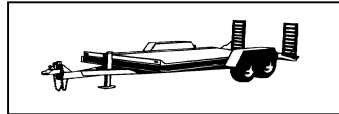

# V.P. Rental, Sales, & Service

www.villeplatterental.com

805 W. Dardeau St.

Phone: (337) 363-0461

Item	Minimum	1 Day	1 Week	4 Weeks
<b>176 SURVEYING &amp; MEASURING EQUIPMENT</b>				
Transit, w/Tripod and Stick	25.00	40.00	160.00	480.00
<b>186 TRAILERS</b>				
<b>Trailer Low Boy Flat Bed 16 ft.</b> (2) 7,000Lb. Cap. (light duty 82 ½+wide and heavy duty 75 ½+wide) w/o Equipment Rental	40.00	55.00	220.00	660.00
<b>Trailer 20ft. Heavy Duty (for Kubota And Excavator)</b> 12,000 Lb. Cap. Electric Brakes 2 5/16in. Ball				
With Equipment Rental	55.00	75.00	300.00	900.00
W/O Equipment Rental	80.00	100.00	400.00	1,200.00
<b>Trailer Short term 10 ft. 3,500 Lb. Cap</b>	\$20.00 (1hr limit)			
<i>Cust del to vp rental <u>max 1h each</u></i>				
<b>125 Tow Dolly</b>	48.00	65.00	220.00	660.00
\$10.00 strap deposit MAX. WIDTH 76+ MAX. WEIGHT 4300 LBS.				
<b>Trailer Dump, Big Tex (ball 2 5/16+)</b> 6000lb capacity 4.3 cubic yards Has Electric Brakes	70.00	85.00	340.00	1020.00
<b>Trailer Binders &amp; Chain</b>				
With Equipment		6.00	18.00	54.00
Without Equipment		12.00	36.00	108.00
<b>Trailer Hitch Balls 2-in. to 2 5/16-in.</b>		3.00	12.00	36.00
<b>Trailer Receiver w/ ball</b>		6.00	24.00	72.00
<b>Trailer Light Wiring Adapter</b>		3.00	12.00	36.00

**When Renting Large trailer with equipment, rental fee will be \$55.00 (1/2 day) and \$75.00 (1 day)**

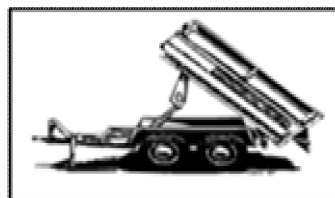
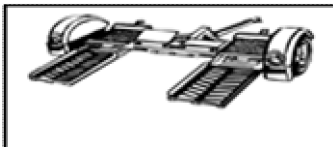

# V.P. Rental, Sales, & Service

www.villeplatterental.com

805 W. Dardeau St.

Phone: (337) 363-0461

Item	Minimum	1 Day	1 Week	4 Weeks
<b>109 WALLPAPER</b>				
Steamer w/ Perforator	15.00	20.00	80.00	240.00

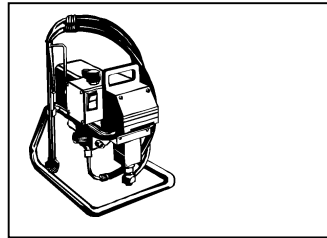

## 110 WATER PUMPS (Gallons Per Hour)

### Submersible

2+Sump (electric) 2000 G.P.H.	30.00	40.00	160.00	480.00
¾+Sump (electric)	12.00	20.00	80.00	240.00
w/10qelevation- 1000 G.P.H. w/15qelevation- 840 G.P.H. w/20qelevation- 520 G.P.H.				

### Water

2+(gas) 8000 G.P.H	35.00	45.00	180.00	540.00
3+(gas) 15,000 G.P.H	40.00	55.00	220.00	660.00

### Trash

3+(gas) 15,000 G.P.H	50.00	65.00	260.00	780.00
----------------------	-------	-------	--------	--------

### Pool 2+suction hose

### Hoses

Discharge Hose				
2-in. x 50 ft. or 25q		8.00	32.00	96.00
3-in. x 50 ft.		8.00	32.00	96.00



# V.P. Rental, Sales, & Service

www.villeplatterental.com

805 W. Dardeau St.

Phone: (337) 363-0461

Item	Minimum	1 Day	1 Week	4 Weeks
110 HYDROSTATIC MANUAL TEST PUMP 1000psi Hydrostatic test pump		35.00	140.00	420.00

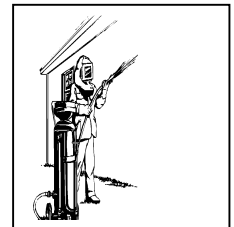
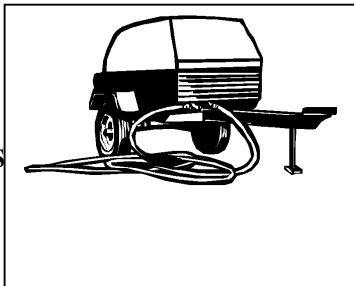
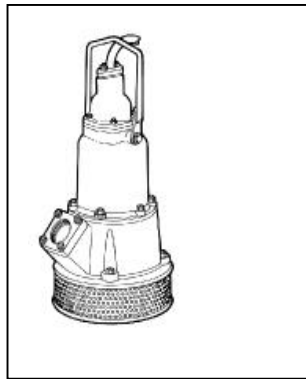
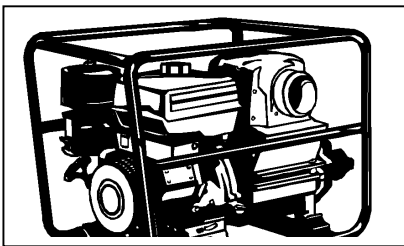

## 495 FLOOR CHEMICALS

Shipp All In One Cleans & Deodorizes Carpets & Upholstery	9.95 per quart 16.95 per gallon
Shipp Chem-Strip Cleaner & Floor Finish Remover	15.95 per gallon

# V.P. Rental, Sales, & Service

www.villeplatterental.com

805 W. Dardeau St.

Phone: (337) 363-0461

Item	Minimum	1 Day	1 Week	4 Weeks
<b>CYLINDER GASES</b> (Cylinder Rentals can be set up for monthly, quarterly) <b>\$75.00 Deposit on all bottles.</b>				
<b>220</b>	<b>Oxygen</b>			
	Large-----	19.72		
	Medium-----	13.99	*Discounts may apply on oxygen price depending on amount used.	
	R20-----inside-----	11.39		
	R40-----inside-----	13.85		
	R80 Extra Large Inside-----	15.40		
<b>221</b>	<b>Acetylene</b>			
	X-Large (dock)-----	-0.49 per cubic foot	-----[approx. 260 per cyl.]	
	Large (dock)-----	0.49 per cubic foot	-----[approx. 115-145 per cyl.]	
	B (Large)----- inside	29.85		
	MC (Small)-----inside	19.27		
<b>224</b>	<b>Helium</b>			
	Large (225-250 balloons)-----	135.95		
	Medium (125 balloons)-----	call		
	Small (75 balloons)-----	call		
<b>222</b>	<b>Argon</b>			
	Large-----	44.85		
	Medium-----	36.69		
	Small-----	27.47		
<b>228</b>	<b>75% / 25% Mig Mix</b>			
	Large-----	44.85		
	Medium-----	37.85		
	Small-----	28.96		
<b>227</b>	<b>Tri-Mix</b>			
	Large-----	call		
<b>223</b>	<b>CO2</b>			
	Outside-----	call		
	Inside-----	call		
<b>225</b>	<b>Nitrogen</b>			
	Large-----	call		
	Medium-----	15.94		
	Inside R40-----	18.35		
<b>229</b>	<b>Regulators</b>			
	With Gauge	\$16.00 per month		
	Without Gauge	\$12.00 per month		

**Price good through 1/31/14 CALL FOR CURRENT PRICE.**

# V.P. Rental, Sales, & Service

www.villeplatterental.com

805 W. Dardeau St.

Phone: (337) 363-0461

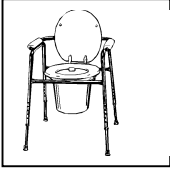
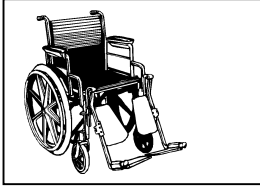
Item	Minimum	1 Day	1 Week	4 Weeks
<b>235 MEDICAL EQUIPMENT</b>				
Crutches		10.00	15.00	50.00
Cane Walking				15.00
Wheelchair (manual)		25.00	50.00	100.00
Wheelchair (electric)		100.00	200.00	400.00
Walker			15.00	45.00
Commode Bedside			15.00	45.00
 				
<b>PARTY EQUIPMENT</b>				
<b>210</b> Chairs Folding metal		.92	3.67	11.04
Tables				
8 ft. Long (15)		15.00	60.00	180.00
60-in. (5ft.) round (13)		15.00	60.00	180.00
48-in. (4ft.) round (5)		10.00	40.00	120.00
<b>208</b> Fountains				
Champagne 3 & 5 Gallon	<b>\$20.00 Deposit</b>	40.00	160.00	480.00
<b>207</b> Wine / Champagne Bucket		8.00	32.00	96.00
<b>205</b> Archways				
Lattice Folding Panels (WHITE)		10.00	40.00	120.00
Brass		20.00	80.00	240.00
<b>207</b> Punch Bowl Silver Ladle comes separate		10.00	40.00	120.00
<b>205</b> Candelabra Spiral		25.00	100.00	300.00
Candles .65 each (STICKS)				
<b>207</b> <b>Crawfish Boiling Equipment</b>				
<b>Burner Package</b>		40.00	120.00	360.00
Package includes; pot, burner & 5 Gal. Propane				
Pot		10.00	40.00	120.00
Burner		15.00	60.00	180.00
5 Gal. Propane (exchange)	\$25.46			
Jelled fuel	1.00 each			

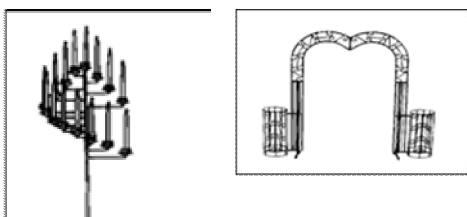

# V.P. Rental, Sales, & Service

[www.villeplatterental.com](http://www.villeplatterental.com)

805 W. Dardeau St.

Phone: (337) 363-0461